

60H+ HRV

Part no. 41652 (TOP PORTS)

Part no. 41650 (SIDE PORTS)

64 to 115 CFM (0.4 in. w.g.)



VB0229

A VERSATILE AND COMPACT PLATFORM OFFERING EVEN MORE POWER

The 60H+ HRV is providing 17 cfm more than the 60H HRV making it suitable for larger ventilation needs. This 115-cfm HRV is also ENERGY STAR® qualified. Still, it offers the same ease of installation associated to the 60H series.

Its operation can be interlocked with an existing furnace without adding an extra relay. Also, for more convenience, its latches can be relocated from sides to front (as shown on unit picture). This compact, lightweight, and powerful unit is the ideal choice for small single-family homes, high rise residential building and other limited space applications.

- Versatile horizontal or vertical port configuration
- Removable terminal block to ease auxiliary wall control connections
- Integrated pressure taps, if balancing required by building code
- ENERGY STAR® qualified

REPAIRS AND MAINTENANCE

All parts of the 60H+ HRV that could need maintenance can be removed in less than 5 minutes, allowing direct access for easy repairs. The PSC motors are permanently lubricated. Finally, the removable electrical drawer with pull-out PCB assembly allows easy access for maintenance of major sub-components.

WARRANTY

The 60H+ HRV is protected by a 5-year warranty on parts only. The heat recovery core is covered by a limited lifetime warranty, with the original proof of purchase.

Available at:



HEAT RECOVERY VENTILATOR

Controls

- This unit is very simple to operate. Once it is installed, press on its push button, located on the bottom of the unit, to activate it. Press once for low speed, once again for high speed, and once more to stop it.
- For more convenience, this unit can also be controlled by an optional main control. For a complete list of optional main and auxiliary controls available, refer to the **Wall Control Compatibility Chart** on last pages of wall controls specification sheet, available at www.vanee.ca.
- For more details about controls, refer to the **Main and auxiliary wall controls** user guide, also available at www.vanee.ca.

Options

- Complete line of registers and diffusers
- Electric duct heater
- Metal tandem hood (part no. 14695)

Homeshield™ Defrosting System

The 60H+ HRV uses a unique defrosting method. No negative pressure is created by air exhausted to outdoors, as the air is recirculated into the house, helping to prevent any backdraft.

OUTDOOR TEMPERATURE		DEFROST CYCLE (IN MINUTES)
°C	°F	DEFROST/ OPERATION
WARMER THAN -5	WARMER THAN 23	NO DEFROST
-5 TO -27	23 TO -17	8/25
-27 & LESS	-17 & LESS	10/22

Heat Recovery Core

Dimensions: 13" x 19" x 6 7/8" (33 cm x 48.3 cm x 17.3 cm)

Exchange surface: 55 ft.² (5.1 m²)

Weight: 3.75 lb. (1.7 kg)

Material: Polypropylene

Type: Cross flow

Warranty: Limited lifetime

Requirements and standards

- Complies with the UL 1812 requirements regulating the installation of Heat Recovery Ventilators
- Complies with the CSA C22.2 no. 113 Standard applicable to ventilators
- Complies with CSA C444 requirements regulating the installation of Heat Recovery Ventilators
- Technical data was obtained from published results of tests relating to CSA C439 Standards
- HVI certified and ENERGY STAR® qualified

DIMENSIONS: 60H+ HRV (PORTS ON SIDES)

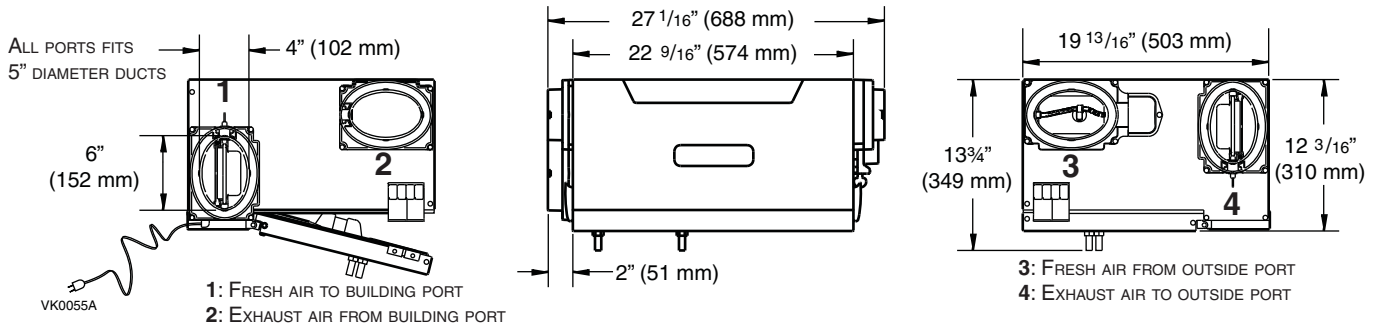

VENTILATION PERFORMANCE

EXTERNAL STATIC PRESSURE		NET SUPPLY AIR FLOW			GROSS AIR FLOW					
					SUPPLY			EXHAUST		
PA	IN. W.G.	L/S	CFM	M ³ /H	L/S	CFM	M ³ /H	L/S	CFM	M ³ /H
25	0.1	62	131	223	62	132	224	63	134	228
50	0.2	59	126	214	60	127	216	60	127	216
75	0.3	56	119	202	56	120	204	58	123	209
100	0.4	54	115	195	54	116	197	55	117	199
125	0.5	50	107	182	51	108	183	53	112	190
150	0.6	49	103	175	49	104	177	51	107	182
175	0.7	46	97	165	46	98	167	48	102	173
200	0.8	44	93	158	44	94	160	45	95	161
225	0.9	41	86	146	41	87	148	42	88	150
250	1.0	40	84	143	40	85	144	40	85	144

ENERGY PERFORMANCE

SUPPLY TEMPERATURE		NET AIR FLOW			POWER CONSUMED WATTS	SENSIBLE RECOVERY EFFICIENCY	APPARENT SENSIBLE EFFECTIVENESS	LATENT RECOVERY/ MOISTURE TRANSFER
°C	°F	L/S	CFM	M ³ /H				
HEATING								
0	32	23	50	85	43	65	74	0.01
0	32	30	64	109	58	62	70	0.01
0	32	39	83	141	70	59	66	0.01
-25	-13	23	48	82	56	60	78	0.01
-25	-13	30	64	109	64	55	72	0
COOLING								
35	95	-	-	-	-	TOTAL RECOVERY EFFICIENCY NOT TESTED		

60H+ HRV (PORTS ON TOP)

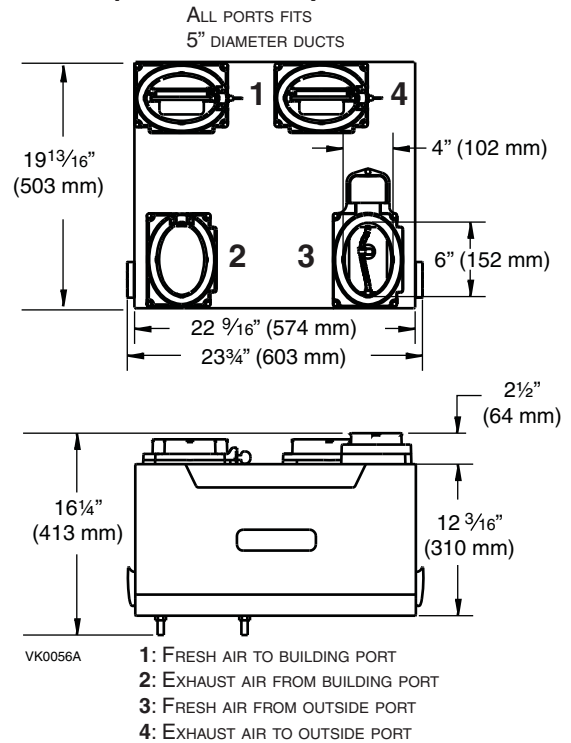

NOTE: All specifications are subject to change without notice.

SPECIFICATIONS

- Model: 60H+ HRV
- Part number top ports: 41652
- Part number side ports: 41650
- Total assembled weight (including polypropylene core): 42 lb. (19 kg)
- Oval shaped ports; fit 5" diameter ducts
- Drain: 1/2" (1.2 cm) fittings with 10 ft. (3 m) PVC drain hose
- Core filters: 30 ppi washable foam 10.5" x 6.75" x 0.5" (26.7 cm x 17.2 cm x 1.3 cm)
- Housing: Pre-painted steel
- Insulation: Expanded polystyrene
- Mounting: Suspension by chains and springs
- Supply and exhaust blower motor: 2 motors
 - Protection type: Thermally protected
 - Insulation class: B
- Speed control on unit: Low & high speeds. Other modes available with main and optional wall controls
- Heat recovery core:
 - Heat exchange surface area: 55 ft.² (5.1 m²)
 - Type/Material: Crossflow/Polypropylene
- Unit electrical characteristics:

Volts	Frequency	Ampere	Watts
120	60 Hz	1.00	120

Project:	REMARKS
Location:	
Part Number:	
Qty.:	
Submitted by:	Date:



Residential Products Group, 550 Lemire Blvd., Drummondville, Qc, Canada J2C 7W9 - Tel.: 1-800-567-3855 Fax 1-800-567-1715



www.vanee.ca

60H+HRVd150407